



Hand-Held Scarifiers



Needleguns



Walk-Behind Scarifiers



Impact Tools



Sanders



Specialty Tools



Industrial Vacuums



# FX-Flushplate

Hand-held Rotary Scarifier  
*Electric w/Standard & Heavy Duty Motor*



110.226



110.2233

### Electric FX-Flushplate Configurations

Part	Description	Hub(s) Included	Accessories Furnished
<b>Standard Motor</b>			
110.226	FX System	Reloadable Cutter, Roto-Peen, and Roto-Hammer	Tool kit and carrying case.
110.222	FX w/Roto-Peen	Roto-Peen*	Tool kit
110.2236	FX w/Reloadable Cutter	Cutter, Reloadable	Tool kit
110.221	FX Bare	None	None
<b>Heavy Duty Motor*</b>			
110.2233	FX w/Reloadable Cutter	Cutter, Reloadable	Tool kit
110.223	FX w/Welded Cutter	Cutter, Welded	Tool kit
110.2212	FX Bare	None	None

\*Note: Roto-Peen *can not* be used with Heavy Duty motor.

### DESCO Mfg. Co., Inc.

23031 Arroyo Vista • Rancho Santa Margarita, CA 92688  
949.858.7400 • 949.858.9141 fax • 800.337.2648 toll free  
www.descomfg.com • info@descomfg.com

# Contents

<b>CHAPTER 1 – GENERAL INFORMATION .....</b>	<b>1</b>
1.1 INTRODUCTION.....	1
1.2 PURPOSE AND FUNCTION .....	1
1.3 CAPABILITIES .....	1
1.4 SPECIFICATIONS .....	2
1.5 PREPARATION FOR USE.....	2
1.6 CONSUMABLES AND ACCESSORIES .....	2
<b>CHAPTER 2 – SAFETY PRECAUTIONS .....</b>	<b>3</b>
2.1 READ OPERATING INSTRUCTIONS .....	3
2.2 ALWAYS WEAR APPROVED EYE PROTECTION .....	3
2.3 HEARING PROTECTION IS RECOMMENDED.....	3
2.4 AVOID PROLONGED EXPOSURE TO VIBRATION.....	3
2.5 POWER REQUIRED .....	3
2.6 WORK AREA .....	4
2.7 PERSONAL SAFETY .....	4
2.8 TOOL USE AND CARE .....	4
<b>CHAPTER 3 – OPERATING INSTRUCTIONS.....</b>	<b>5</b>
3.1 PRE-OPERATION.....	5
3.2 OPERATION .....	6
3.2.1 <i>Power On/Off</i> .....	6
3.2.2 <i>Starting the Tool</i> .....	6
3.3.3 <i>Working the Surface</i> .....	7
3.3.4 <i>Roto-Peen Cautions</i> .....	8
3.3 POST-OPERATION AND STOWAGE.....	8
<b>CHAPTER 4 – MAINTENANCE INSTRUCTIONS.....</b>	<b>9</b>
4.1 CLEANING AND LUBRICATION .....	9
4.2 PERFORMANCE VERIFICATION .....	9
4.3 REMOVAL AND REPLACEMENT OF HUB ASSEMBLIES .....	9
4.4 RELOAD CUTTER HUB USING RE-LOAD KIT .....	10
4.5 RELOAD ROTO-PEEN FLAPS USING RE-LOAD KIT .....	11
<b>CHAPTER 5 – TROUBLESHOOTING.....</b>	<b>13</b>
<b>CHAPTER 6 – SCHEMATICS.....</b>	<b>14</b>
TOOL BODY AND MAJOR COMPONENTS SCHEMATIC .....	14
ELECTRIC MOTOR SCHEMATIC (STANDARD MOTOR).....	15
ELECTRIC MOTOR SCHEMATIC (HEAVY DUTY MOTOR) .....	17

## CHAPTER 1 – General Information

### 1.1 Introduction

This publication describes the Desco FX-Flushplate hand held rotary scarifier. Topics covered in this manual include operator safety, proper operation, maintenance procedures, and troubleshooting.

### 1.2 Purpose and Function

The machine is a lightweight, portable, electric-powered tool designed for the removal of scale, paint, and corrosion from hard surfaces using a rotating head fitted with Roto-Hammers, Cutters or Roto-Peen flaps.

### 1.3 Capabilities

The machine can be used to remove paint, primer, nonskid, corrosion or contaminants, and to feather paint on many surfaces, including steel, aluminum or concrete. The FX-Flushplate provides high productivity for horizontal surfaces where weight is not a consideration. When weight is an issue, such as vertical or overhead surfaces, the Mini-Flushplate is recommended. The interchangeable hub assemblies excel at these tasks.



**Cutters** are used to remove heavy coatings including epoxy and elastomeric type coatings, mastic removal, non-skid removal, as well as concrete scarification.

Two types of cutter hubs are available:

- 1) Welded – when cutters wear out the hub is discarded (pictured).
- 2) Reloadable – when cutters wear out, the hub is reloaded. A reload kit is available which includes cutters and other wear parts.



**Roto-Hammers** are very effective in removing fracturable coatings. Due to their design, they are also ideal for removing coatings from irregular surfaces or surfaces with holes or protruding objects such as nuts, bolts, welds and tie downs. Due to the Roto-Hammer design, they perform much like a needlegun in terms of both profile and versatility. Hammers will step over obstacles like bolt heads and step into depressions, in the same manner as the needles of a needlegun.



**Roto-Peen Flaps** are used to remove fracturable coating up to a 20 mil thickness. Roto-Peen was designed to provide a shotblast type profile and meets the 1 to 3 mil profile specified by SSPC SP-11. Roto-Peen is approved for use on steel, aluminum and concrete substrates. Roto-Peen are long wearing when used properly. Proper use includes maintaining proper height adjustment, speed and the avoidance of excessive heat buildup. Roto-Peen is designed for use on flat surfaces and not for running over weld bead or other surfaces with protruding objects. See operating instructions for more information.

**Note:** Roto-peen **can not** be used with heavy duty motor.

## 1.4 Specifications

Item	Motor	
	Standard	Heavy Duty
Power	115v, 1200w	115v, 1725w
Speed (no load)	1,100 – 3,600 rpm (var)	6,600 rpm
Weight (motor, body, no hub)	6.35 lbs.	11.6 lbs.
Length	15"	19.25"
Vacuum Hose Req.:		
Diameter	1-1/2" ID	1-1/2" ID
Length:	10' standard, 25' max	10' standard, 25' max

## 1.5 Preparation for Use

This machine is ready to use when received from the manufacturer. Depending on the tool configuration purchased (see front cover), the tool comes with zero-to-three hubs. If the operator elects to use a different hub from that which comes installed on the machine, he should turn to Chapter 4, paragraph 4.3 for instructions on how to replace the various hubs.

## 1.6 Consumables and Accessories

Part	Description
<b>Interchangable Hubs</b>	
110.032	Hub, Cutter, Reloadable, w/cutters
110.027	Hub, Cutter, welded (not reloadable), w/cutters
110.022	Hub, Roto-Hammer (eq. to a high speed needlegun)
110.054	Hub, Roto-Peen, w/"C" flaps
110.012	Hub, Roto-Peen, w/o flaps
<b>Consumables</b>	
110.033	Reload, cutters
110.006	Reload, Roto-Peen, type "C", (12 pcs, 2"ea.)
<b>Accessories</b>	
110.016	Roto-Peen keeper pin (6 required)
110.047	Roller Kit, for use with Roto-Peen
110.049	Roller (Must purchase 2)
110.001	Replacement Brush Set for Dust Collector. Comes with brush, channels and rivets
500.057	Carry case

## CHAPTER 2 – Safety Precautions



### **WARNING Read and understand all instructions**

Failure to follow all instructions listed below may result in damage to the tool and/or serious personal injury.

### ***2.1 Read Operating Instructions***

Always become familiar with all the instructions and warnings before operating any power tool.

### ***2.2 Always Wear Approved Eye Protection***



Impact resistant eye protection should meet or exceed the standards as set forth in the United States ANSI Z87.1, Occupational and Educational Eye and Face Protection. Look for the marking Z87.1 on your eye protection to insure that it is an approved style. For further information, ANSI Z87.1, Occupational and Educational Eye and Face Protection, is available from the American National Standards Institute, Inc., 11 West 42nd Street, New York, NY 10036.

### ***2.3 Hearing Protection is Recommended***



Hearing protection should be used when the noise level exposure equals or exceeds an 8 hour time-weighted average sound level of 85dBA. Process noise, reflective surfaces, other tools being operated nearby, all add to the noise level present in your work area. If you are unable to determine your noise level exposure, we recommend the use of hearing protection.

### ***2.4 Avoid Prolonged Exposure to Vibration***



Pneumatic tools can vibrate during use. Prolonged exposure to vibration or very repetitive hand and arm movements, can cause injury. Stop using any tool if discomfort, tingling feeling or pain occurs. You should consult your physician before resuming use of the tool.

### ***2.5 Power Required***



This tool is designed to operate at on electricity delivered at 115 volts. The motor is double insulated for safety and does not require grounding for operator safety.

## 2.6 Work Area

1. **Keep work area clean and well lit.** Cluttered benches and dark areas invite accidents.
2. **Do not operate power tools in explosive atmospheres**, such as in the presence of flammable liquids, gasses, or dust. Power tools create sparks which may ignite dust or fumes.
3. **Keep bystanders away** while operating a power tool.

## 2.7 Personal Safety

1. **Stay alert**, watch what you are doing and use common sense when operating a power tool. Do not operate tool when tired or substance impaired.
2. **Dress properly.** Do not wear loose clothing or jewelry. Contain long hair. Keep hair, clothing and hands away from moving parts.
3. **Use safety equipment.** Always wear eye protection. Other precautions may be required depending on the situation. These include: ear protection (ear plugs) vibration protection (gloves), steel toe shoes or hard hats.
4. **Avoid accidental starting.** Be sure the switch is off before attaching to power source.
5. **Do not overreach.** Keep proper footing and balance at all times.

## 2.8 Tool Use and Care

1. **Secure the work.** Use clamps or other securing method to firmly hold work to a stable platform. Do not attempt to hold work in one hand and operate the tool with the other hand.
2. **Do not force tool.** Apply light hold down pressure and let the tool do the work. Use the correct tool for your application.
3. **Do not tape trigger closed** to fashion a trigger lock. If you drop or otherwise lose control of the tool, it will continue to run and may cause dangerous results.
4. **Disconnect from power source before making adjustments** or changing accessories. Failure to disconnect may result in injury if the tool were to accidentally start while adjusting.
5. **Store tools out of reach of untrained persons.** Tools are dangerous in the hands of untrained users.
6. **Maintain tools with care.** Keep cutting tools sharp and clean. Properly maintained tools, with sharp cutting edges are less likely to bind and are easier to control.
7. **Check for misaligned or binding of moving parts**, breakage of parts, and any other condition that may affect the tool's operation. If damaged, have the tool serviced before using. Many accidents are caused by poorly maintained tools.

## CHAPTER 3 – Operating Instructions

### 3.1 Pre-Operation

- **Hub** – Install hub of choice for task. Check consumables for remaining life. Replace consumables as required. See *Inspection and Replacement* below.  
**Note:**
  - 1) **Use rollers** with the roto-peen hub to maintain proper height.
  - 2) **Do not use rollers** with the cutter hub or roto-hammer hub.
  - 3) **Do not use roto-peen** with heavy duty motor.
- **Vacuum** – Connect to power source and connect vacuum hose to tool. Vacuum is **highly recommended** when using **roto-peen** to dissipate heat. Vacuum is optional when using cutters or roto-hammers.
- **Safety** – You have considered the job site environment and implemented safety precautions that are situation appropriate.
- **Inspection and replacement**

Part	Inspection	Replacement
Hammers	Daily	Replace when worn (when hammer doesn't strike surface), or when hammer is broken.
Cutters	Daily	Replace when worn to within 1/8" of solid core.
Roto-Peen flaps	Daily	Replace when tips are worn off or fabric is torn.





## 3.2 Operation

When setup steps are complete, you are ready to operate the tool. The following are step-by-step procedures for operating the FX-Flushplate hand-held rotary scarifier.

### 3.2.1 Power On/Off

Power is controlled with a throttle lever which has a double safety lock-off feature designed to prevent accidental starting of the tool. To operate, slide the lock-out pin forward then squeeze the lever. To stop, release the lever.

The *power on/off sequence* is **critical** to effective dust containment.

Sequence	First Action	Second Action
On	Vacuum On 	Tool On 
Off	Tool Off  Off: Release Lever	Vacuum Off 

### 3.2.2 Starting the Tool

- A. **Grasp Firmly** – with both hands. Left on handle, right on motor.
- B. **Heel Down/Toe Up** – The rear of the tool body should be touching the surface while the front is elevated about 2" to allow the hub to spin free.
- C. **Power On** – Start the tool using the above power on sequence. Continue to hold the front up until the motor comes up to operating speed.
- D. **Level Tool** – With motor up to speed, ease the front down to the surface to engage the abrasive.

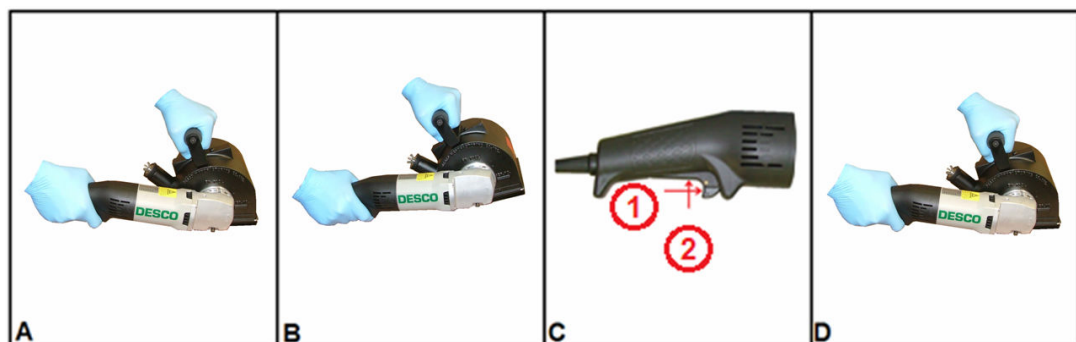



### 3.3.3 Working the Surface

- A. Grid Pattern** – Move tool in a system of grid patterns. Complete one grid before moving to the next. Cut a swath, move to the right 4 inches and repeat. Use a stroke length that is convenient to the surface and your arm length.
- B. Cut on Back Stroke** – While the tool will cut in either the forward or backward direction, the backward direction is more effective due to the direction of rotation.
- C. Skew the Stroke** – When using Roto-Peen, hold the machine angled about 5 to 10 degrees from straight. Angling (skewed) results in a cleaner surface with less streaking than a straight motion.
- D. Work the Edge** – Overlap each stroke to maximize productivity. The edge refers to the freshly cut edge left by a stroke of the tool. The very first pass is more difficult because it has to break through the coating. Subsequent passes are more efficient because the coating surface has been broken.

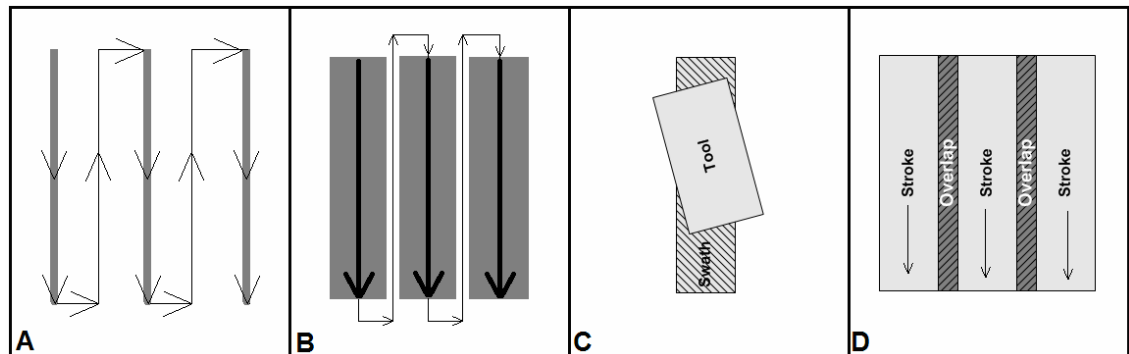

### 3.3.4 Roto-Peen Cautions

Roto-peen flaps are easily damaged when not used properly. Please observe the following precautions when using Roto-Peen.

- **Tool Height** – to set Roto-Peen at proper height, tool must always be used with supplied rollers. When operating tool, both rollers must be in contact with surface.
- **Tool Speed** – to insure Roto-Peen is operated at proper speed, tool speed control dial must never be turned higher than number 4. **DO NOT** use Roto-Peen with heavy duty motor.
- **Vacuum** – Using a vacuum with Roto-Peen is highly recommended to generate air flow to dissipate heat. Failure to use vacuum with Roto-Peen may result in premature failure of the Roto-Peen flaps.
- **Objects** – When using Roto-Peen, **DO NOT** run the machine over bolt heads or other protruding objects.
- **Sharp Edges** – When using Roto-Peen on an area which has a sharp edge, never allow flaps to rotate onto an edge; this will damage them. To clean the edge, move the machine so that flaps are rotating off the edge, or operate parallel to the edge.

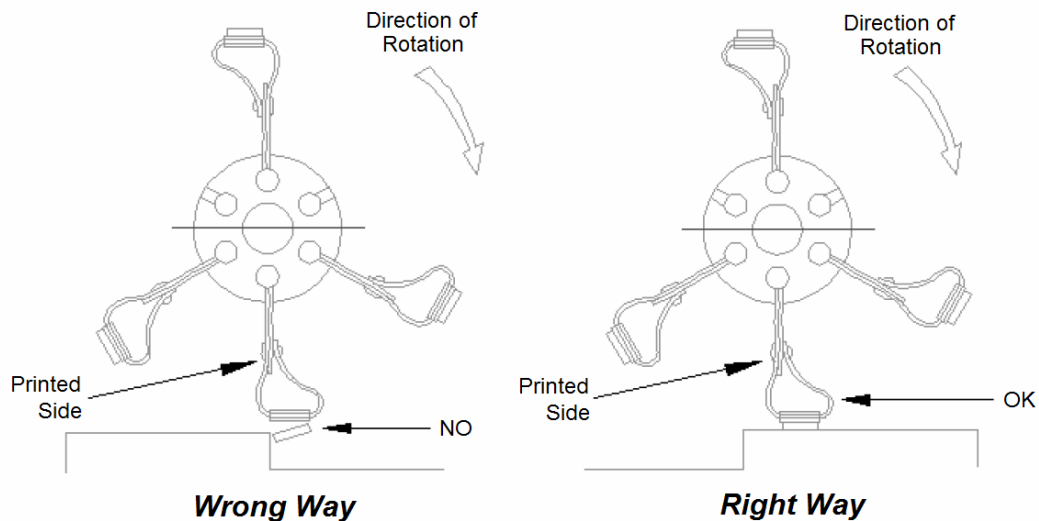

### 3.3 Post-Operation and Stowage

Wipe off all dust and dirt with a dry rag. Coil power cord and secure with a piece of string or wire.

## CHAPTER 4 – Maintenance Instructions

### 4.1 Cleaning and Lubrication

- **Cleaning** – Clean the FX-flushplate after each use by wiping off all dust and dirt with a clean, dry cloth.
- **Lubrication** – There are no external lubrication points to be serviced.

### 4.2 Performance Verification

Check “ON/OFF” handle to make sure the double safety lock-off lever is operating properly.

### 4.3 Removal and Replacement of Hub Assemblies

**WARNING** – Always disconnect tool from power supply before performing any maintenance or inspection operation.

Hubs are removed and replaced to facilitate reloading consumables or adapting to a new application better served by a different abrasive. Change hubs using the following procedure.

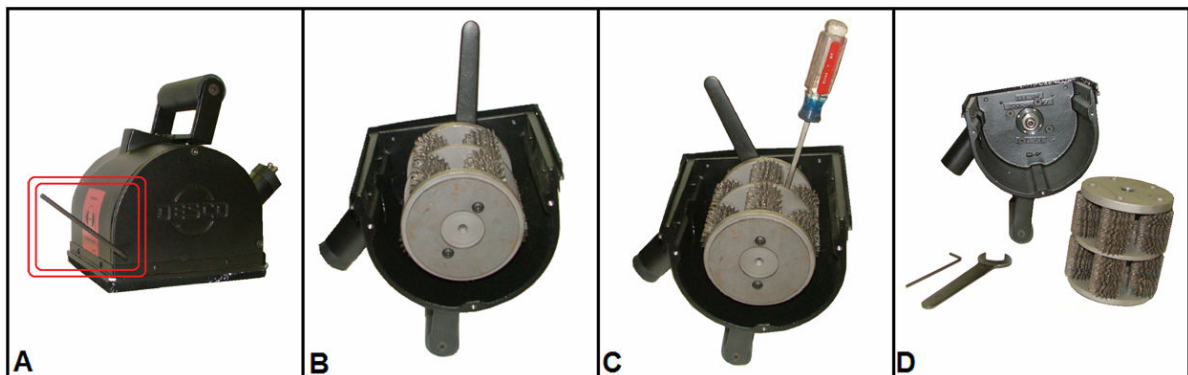

- Remove Side Cover** – Using the supplied Allen wrench, remove the three (3) Allen head bolts. Set cover aside. Save bolts for re-assembly.
- Lock the Spindle** – Using the supplied end wrench, hold the spindle in place. Do so by inserting the wrench between the hub and the tool body.  
Note: The electric motor has an integrated spindle lock but using it is not recommended. The preferred method of locking the spindle is by using the wrench as stated above.
- Remove Hub** – While holding the spindle locked with the end wrench, turn the hub in a counter-clockwise direction until it separates from the spindle. If the hub is too tight to turn by hand, insert a large screw driver to provide greater leverage.
- Replace Hub** – Install new hub by reversing the dis-assembly procedure.

## 4.4 Reload Cutter Hub using Re-load Kit

Begin by removing the hub as described in paragraph 4.3.

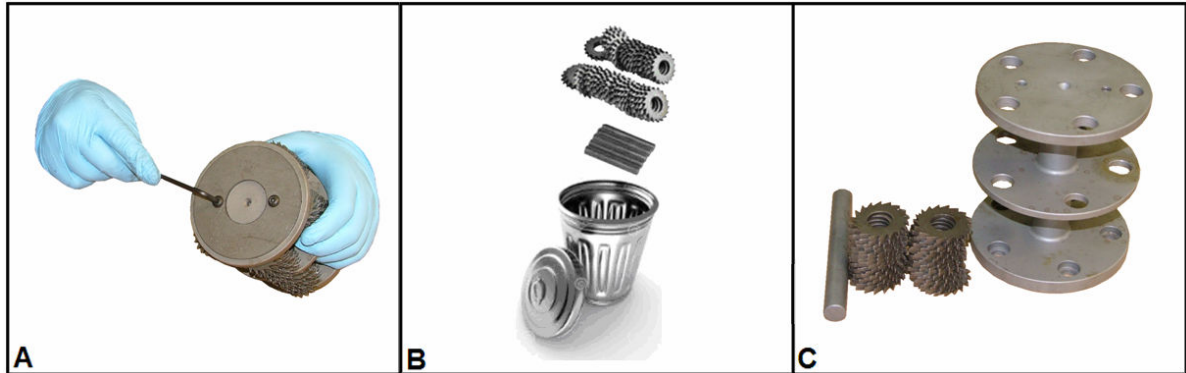

- A. *Remove End Plate* – Remove the two (2) Allen head bolts securing the end plate. Set aside end plate for later use.
- B. *Remove & Discard Cutters* – Discard old cutters, pins and Allen bolts.
- C. *Count Cutters* – Count into stacks of 15 cutters and hold the first stack in your hand.

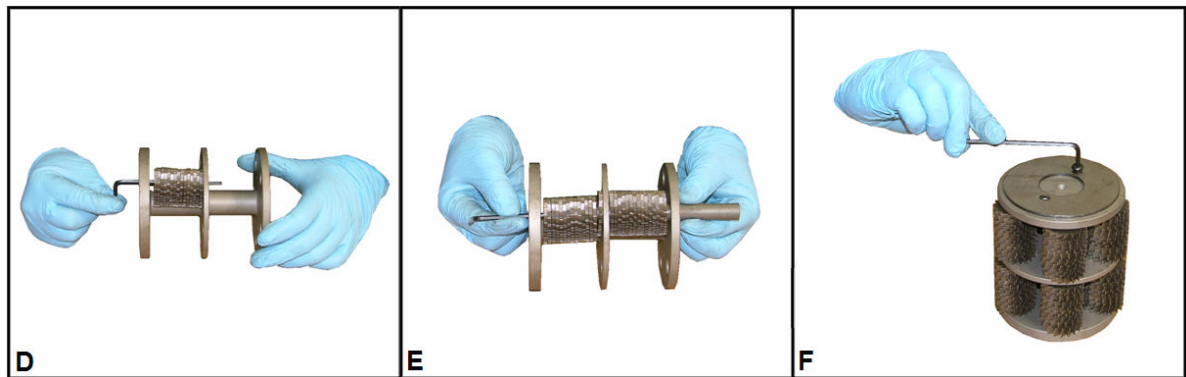

- D. Use the Allen wrench to temporarily hold the cutters in place.
- E. Load cutters on opposite side directly on the pin. Then slide pin through hole, pushing out Allen wrench and leaving pin holding cutters. Repeat steps D-E for each row of cutters.
- F. *Replace Cover* – Replace end cover. Secure with new Allen bolts provided.

**Note:** Pins should be replaced when they become bent, worn or otherwise damaged. When using the re-load kit that comes with pins, the pins should be replaced with each cutter load. However, when reloading with bulk cutters, the pins may be reused one time provided that they are undamaged.

## 4.5 Reload Roto-peen Flaps using Re-load Kit

Begin by removing the hub as described in paragraph 4.3.

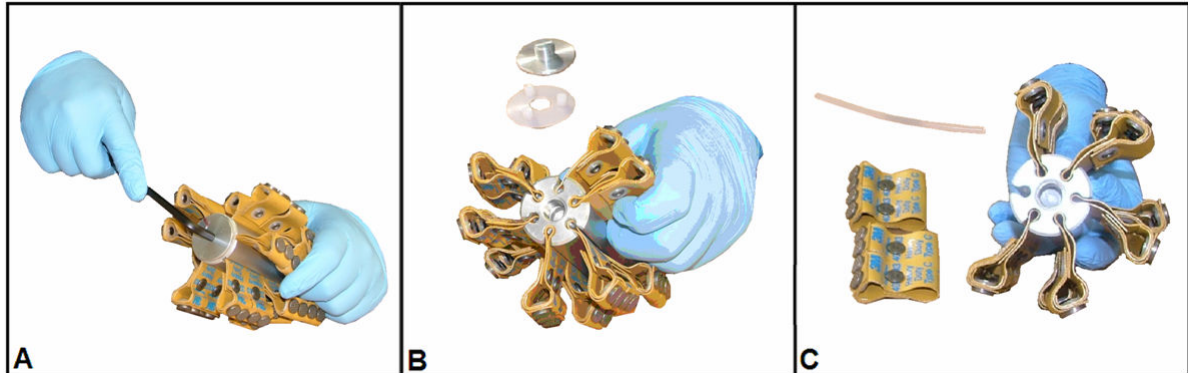

- A. *Loosen* end cap with Allen wrench provided.
- B. *Remove* end cap and spacer. Set aside for later use.
- C. *Remove* and discard old Roto-Peen flaps. Set aside plastic keeper pins for later use.

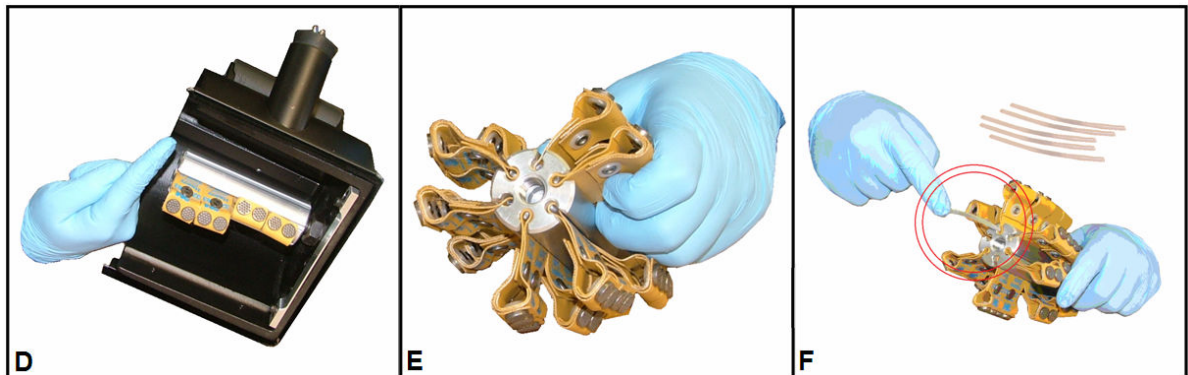

- D. Install **FIRST** new Roto-Peen Flap – While holding the hub with the threaded end next to spindle, install first Roto-Peen flap with lettering facing the vacuum exhaust port. **Roto-Peen flaps are directional. It is critical that they be installed in the correct direction. Use this exhaust port reference as a guide.**
- E. Install **REMAINING** new Roto-Peen Flaps – Insert remaining flaps with the printed side facing the same direction as the first flap.
- F. Install Keeper Pins – Insert keeper pins saved from step C. One pin per flap row is required.

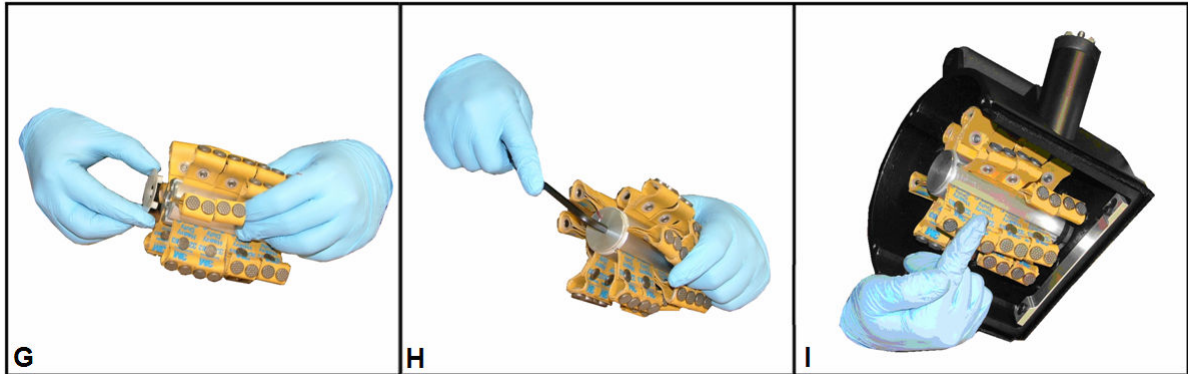

G. *Replace Spacer* – Insert plastic spacer as shown.

H. *Replace end cap* – Secure with Allen wrench. Re-install hub in tool.

**Note:** Rollers must be installed when replacing side cover. They are critical for use with Roto-Peen.

I. *Check Directionality* – With reloaded hub reinstalled, slowly spin hub by hand. Observe that the lettering on all flaps is pointing toward the vacuum exhaust port. Correct if necessary.

**Note:** Be sure to install rollers when using Roto-Peen as shown below.

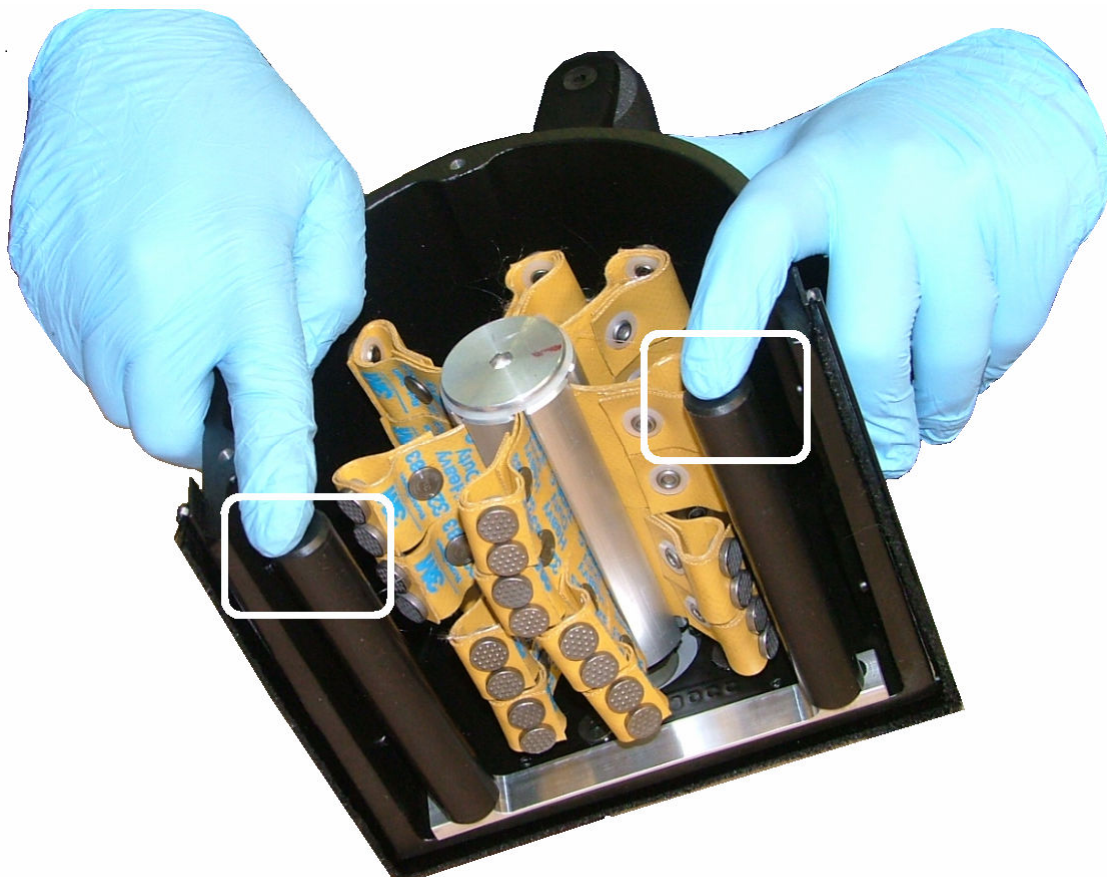

## CHAPTER 5 – Troubleshooting

Malfunction	Probable Cause	Solution
Difficult to remove hub assembly	Nut on shaft arbor loosening	Hold nut in vice with spindle assembly slightly threaded into nut. Place 1 drop of loctite on bottom of threads. Safely turn on tool so threads are securely tightened into nut.
Roto-peen flaps wearing prematurely	Printed side reversed  Speed too fast  Flaps are overheating and metal buttons are separating from flap  Flaps hitting surface on heel side of fabric  Running over bolt heads/weld beads	Reinstall flaps with printed side hitting surface first.  Check speed control dial and set no higher than number 4. Should operate at or below 3,200 RPM. <b>DO NOT</b> use Roto-Peen with heavy duty motor.  Attach vacuum to dust collector attachment to provide airflow and dissipate heat.  Make sure that the rollers are on surface.  Use correct procedure.
Cutters breaking	Bearing down too hard on tool  Using cutters beyond useful life  Tool bouncing on deck	Hold tool with enough pressure to keep in contact surface, but no more. Do not bear down.  Replace cutters when they become ineffective.  Start tool with cutters slightly off the working surface and slowly lower when operating.  When stopping tool, rock the tool back just enough so that cutters are not making contact with surface and turn off motor.
Spindle shaft breaking	Running cutters over protruding objects	Utilize hammer hub assembly.

## CHAPTER 6 – Schematics

### Tool Body and Major Components Schematic

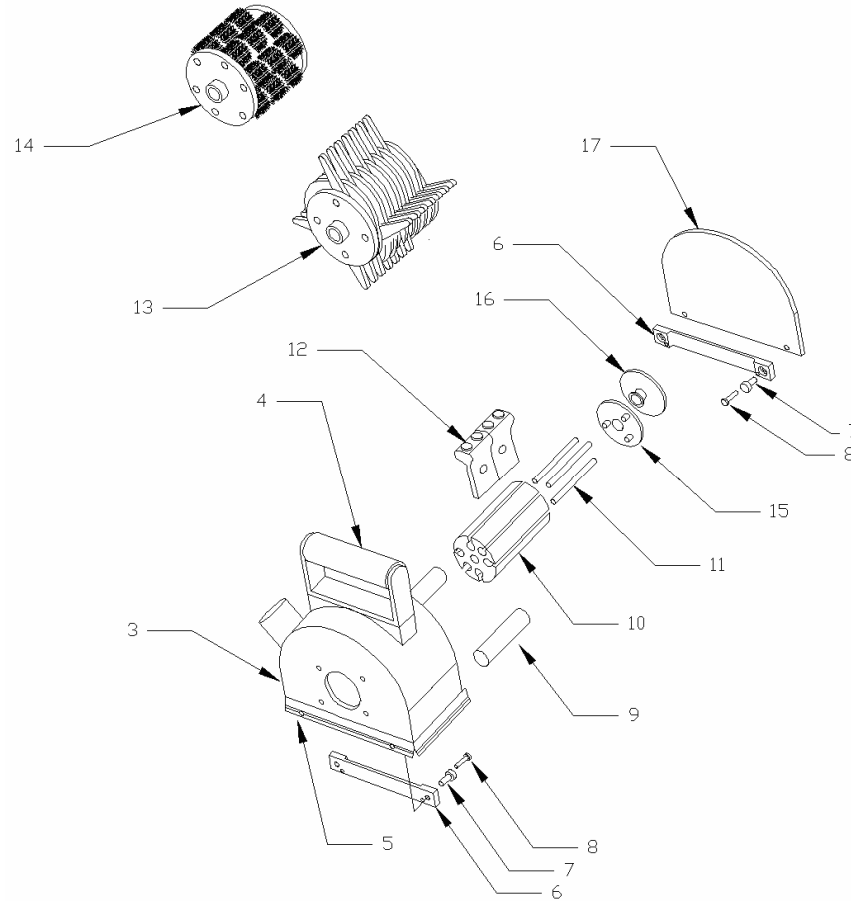

Ref	Part No	Description
1	110.053.2	Electric Motor, <i>standard</i> , (not pictured)
1	110.037	Electric Motor, <i>heavy duty</i> , (not pictured)
3	110.035	Dust Collector, (for electric motor)
4	500.055	Handle Assembly
5	110.001	Replacement Brush Set
-	110.047	Roller Kit (includes items 6-9)
6	110.048	Roller mounting rail
7	550.211	Roller rail mounting spacer
8	550.210	Roller rail securing screw
9	110.049	Roller
10	110.011	Roto-peen hub
11	110.016	Roto-peen, keeper pin
12	820.302	Roto-peen, flap
13	110.022	Hub, hammer
14	110.027	Hub, cutter, welded
14	110.032	Hub, cutter, reloadable (not pictured)
15	500.155	Spacer ring
16	500.068	Roto-peen, hub flange, end cap
17	110.010	Flush Guard. Door. Included in tool body, pn 110.035



## Electric Motor Schematic (Standard Motor)

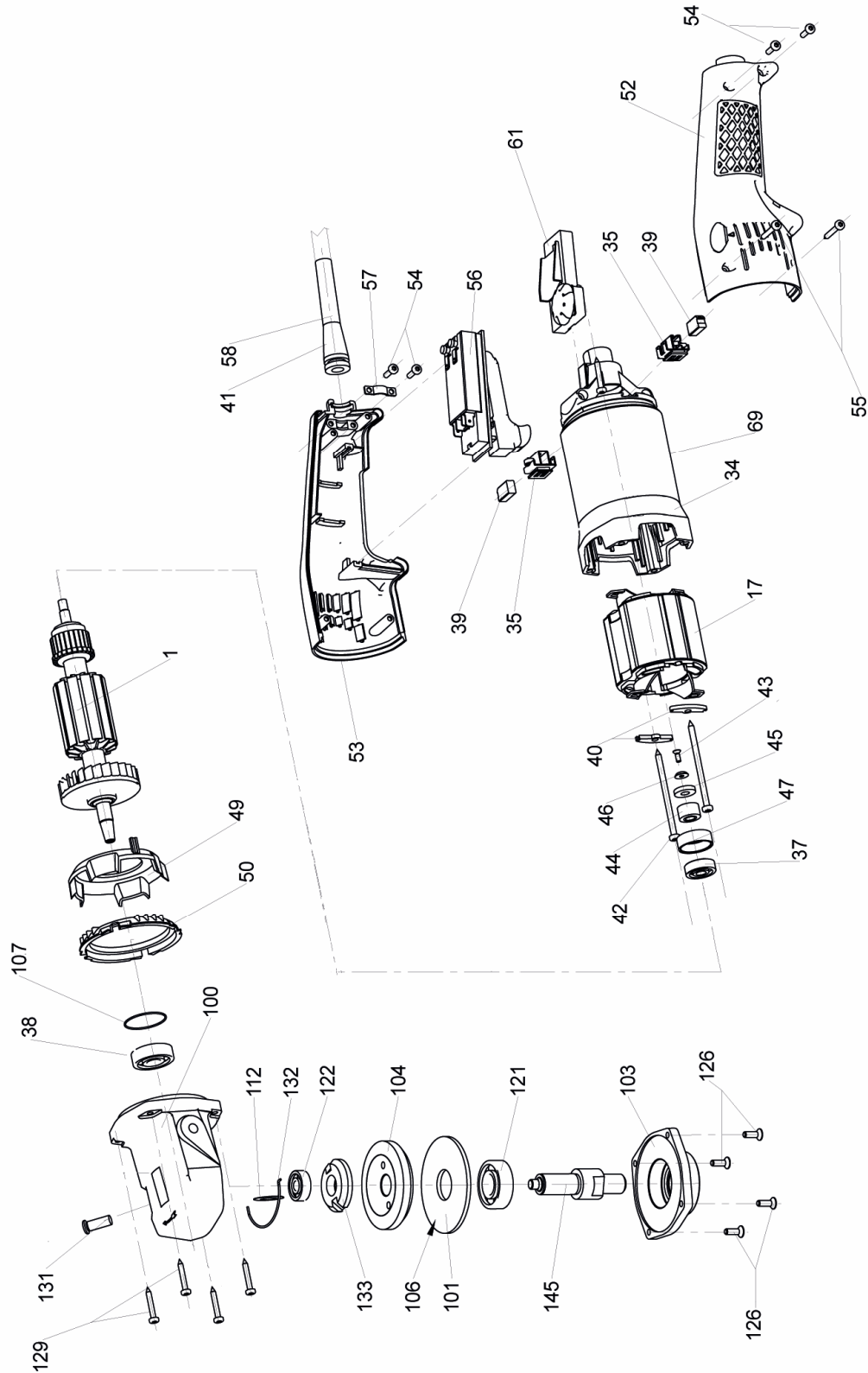

### Electric Motor Parts List, Standard Motor

Ref	Part	Description	Qty
1	550.06474712	Armature	1
17	550.06475002	Stator	1
34	550.30001799	Stator housing	1
35	550.30000702	Carbon brushes holder incl. flange	2
37	550.02768413	Ball bearing	1
38	550.02769682	Ball bearing	1
39	550.30000808	Carbon	2
40	550.30001138	Stator screw fastening	2
41	550.02802901	Anti-kink guard	1
42	550.02801901	Round-head screw	2
43	550.05793701	Damping ring	1
44	550.30000894	Support ring	1
45	550.05728701	Annular magnet	1
46	550.05728901	Washer	1
47	550.02813401	Countersunk screw	1
49	550.30000791	Fan cover	1
50	550.30000790	Eye protection	1
52	550.30000814	Half-shell handle left	1
53	550.30000815	Half-shell handle right	1
54	550.02799712	PT screw	4
55	550.02799516	PT screw	2
56	550.30000816	Switch	1
57	550.03518301	Cable clip	1
58	550.30001884	Power cable	1
61	550.06474802	Electronic control	1
69	550.06474939	Ratings plate	1
100	550.07841402	Angle head	1
101	550.04896901	Washer	1
103	550.04889501	Retainer	1
104	550.05784101	Bevel gear	1
106	550.04896302	Adjusting washer	1
107	550.02766401	Retaining ring	1
112	550.02788201	Disc spring	1
121	550.02767111	Deep-groove ball bearing	1
122	550.02767310	Deep-groove ball bearing	1
126	550.04816303	Countersunk screw	4
129	550.02799516	Sheet metal screw	4
131	550.05761501	Stop pin	1
132	550.05761601	Stop pin spring	1
133	550.05761701	Locking hub	1
145	550.04946702	Spindle 5/8-11 x 30mm	1

## Electric Motor Schematic (Heavy Duty Motor)

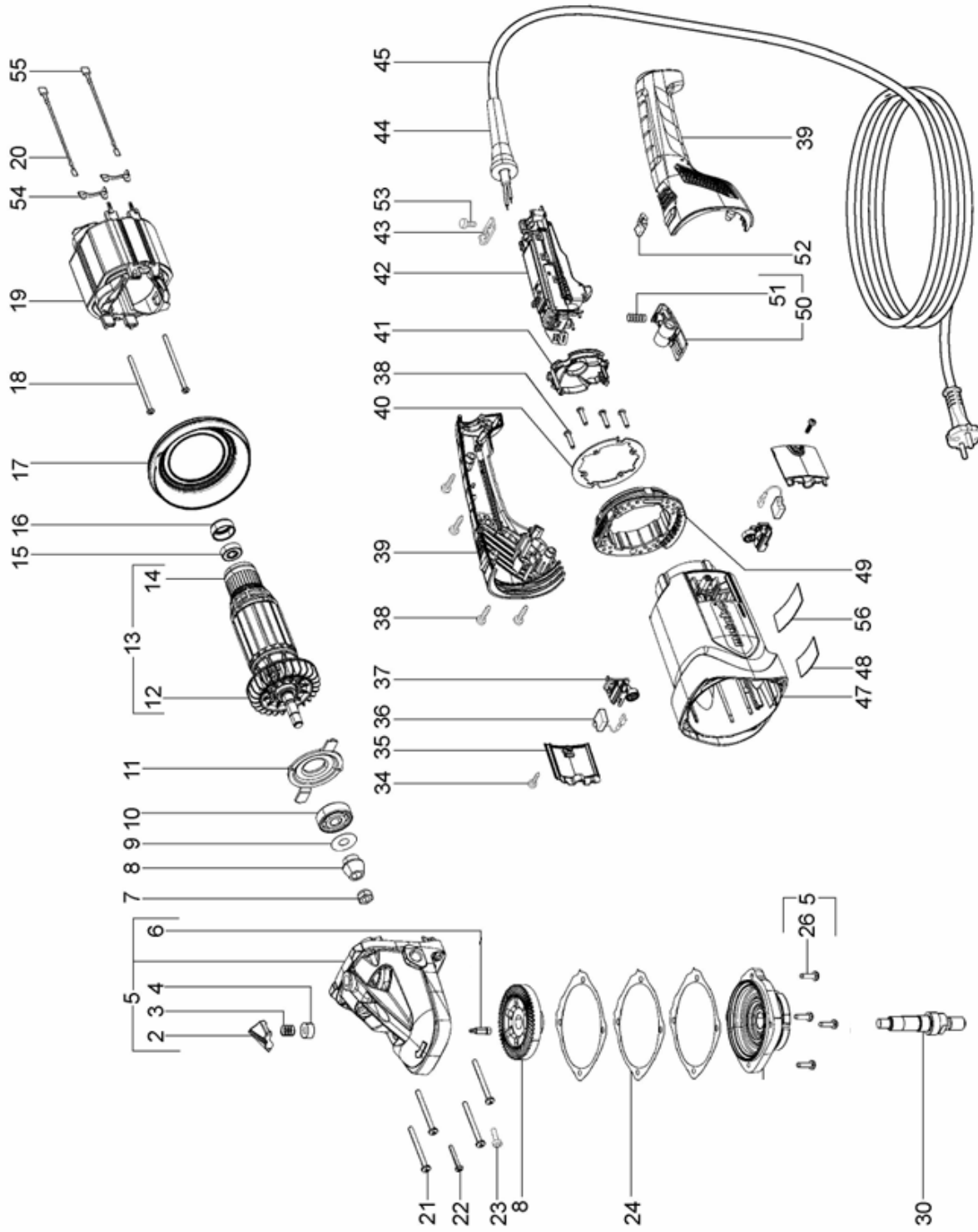

### Electric Motor Parts List (Heavy Duty Motor)

Ref	Part No	Description	Qty
2	343397790	Push button	1
3	342003390	Pressure spring	1
4	341005830	Guide bush	1
5	316045500	Gear housing cpl.	1
6	341515430	Bolt	1
7	341100660	Self locking nut	1
8	316045530	Bevel gear	1
9	141123870	Washer	1
10	143115230	Ball bearing, 12x37x12	1
11	339007280	Fixed bearing cover	1
12	316045560	Fan w. dust guard	1
13	310009490	Armature compl.,120V	1
14	343390630	Sealing washer	1
15	143113400	Ball bearing, 8x22x7	1
16	344094080	Rubber bearing	1
17	339151130	Baffle	1
18	141121680	Self-tap. fill. h. screw	2
19	311009590	Field coil	1
20	344494200	Strand	1
21	141119370	Self-tap. fill. h. screw	4
22	141122020	Fillister head screw	1
23	141119850	Fillister head screw	1
24	339011810	Gasket	3
25	316045550	Gear flange cpl.	1
26	141121640	Fill. head screw(DIN 7985)	4
27	141123890	Fillister head screw,(DIN 7985)	1
28	316045360	protective hood adjustment	1
29	141181500	Circlip	1
30	341604100	Spindle,5/8"	1
34	341702050	Screw	2
35	343395530	Brush holder cover	2
36	316046780	Carbon brush set,120 V	1
37	343000950	Brush guide	2
38	141116020	Self-tap. fill. h. screw	8
39	343395510	Handle (upper+under part)	1
40	339007320	Retaining sheet	1
41	343398250	Edge protection	1
42	343409150	Switch,230V/120V	1
43	339127730	Cable clip	1
44	344094550	Cable sleeve	1
45	344490920	Cable with plug	1
47	315013300	Motor housing	1
48	338049270	Rating plate	1
49	343397490	Damper	1
50	343395520	Locking lever	1
51	342002170	Pressure spring	1
52	343397890	Dummy plug	1
53	141116800	Self-tap. fill. h. screw	1
54	339160850	Contact strap	2
55	344498080	Strand compl.,120V	1
56	338122090	Warning Label 52x22	1